

- Holmberg, David, Kathryn March, and Suryaman Tamang. 1999. Local Production/Local Knowledge: Forced Labour from Below. *Studies in Nepali History and Society* 4(1):5-64.
- Hutton, J. H. 1973 [1943]. *Caste in India*. Bombay: Oxford University Press.
- Khare, R. S. 1984. *The Untouchable as Himself: Ideology, Identity, and Pragmatism among Lucknow Cambarus*. Cambridge: Cambridge University Press.
- March, Kathryn S. 1987. Hospitality, Women, and the Efficacy of Beer. *Food and Footway* 1:351-387.
- Marriot, McKim, and Ronald B. Inden. 1977. Toward an Ethnology of South Asian Caste Systems. In *The New Wind*. K. David, ed. The Hague: Mouton.
- Moffat, Michael. 1979. *An Untouchable Community in South India: Structure and Consensus*. Princeton: Princeton University Press.
- Ortner, Sherry. 1973. Sherpa Purity. *American Anthropologist* 75:49-63.
- Passin, Herbert. 1955. Untouchability in the Far-East. *Monumenta Nipponica* 11(3):247-267.
- Raheja, Gloria Goodwin. 1988. *The Poison in the Gift: Ritual, Prestation, and the Dominant Caste in North India*. Chicago: University of Chicago Press.
- Sahlins, Marshall. 1972. *Stone Age Economics*. Chicago: Aldine-Atherton.
- Sharma, Prayag Raj. 1977. Caste, Social Mobility, and Sanskritization: A Study of Nepal's Old Legal Code. *Kailash* 5:277-290.
- Srinivas, M. N. 1952. *Religion and society among the Coorgs of South India*. Oxford: Clarendon Press.
- Srinivas, M. N. 1966. *Social Change in Modern India*. Berkeley: University of California Press.
- Toffin, Gérard. 1884. Unités de parenté, système d'alliance et de prestations chez les Tamang de l'Ouest (Nepal). *Anthropos* 81:21-45.
- Tyler, Stephen A. 1986. *India: An Anthropological Perspective*. Prospect Heights, Illinois: Waveland Press.

ALL IN THE FAMILY: MONEY, KINSHIP, AND THERAVADA MONASTICISM IN NEPAL

David N. Gellner
(University of Oxford) and
Sarah LeVine (Harvard University)

Historical Background

The figure of the monk—shaven-headed, ochre-robed, intent on enlightenment—is a key symbol in all Buddhism, but it is far more central in some forms or traditions than in others. In the traditional form of Buddhism of the Kathmandu Valley, Nepal, known as Newar Buddhism, the contrast between monasticism as a symbol and monasticism in practice is perhaps greater than anywhere. The story of the Buddha's renunciation was well known, in the Mahayanist version given in the *Lalitavistara*. The main shrines of Newar Buddhism nearly all contain statues of Shakyamuni Buddha himself and main Buddha shrine is usually flanked by the Buddha's two main monastic disciples, Shariputra and Maudgalyayana.¹ These shrines are found in temple complexes, usually small courtyards given over to Buddhist monuments, known colloquially in Nepal Bhasa (Newari), the local language of the Kathmandu Valley, as *bahah* or *bahi*, and honorifically by the Sanskrit and Pali term, *vihara*. In other words, from the point of view of the tradition, these sacred Buddhist courtyards are monasteries and the ritual specialists who inhabited and owned them are monks. And yet there are no full-time monastics in Newar Buddhism. Instead there is a sacerdotal caste of married domestic and temple priests, the Vajracharyas and Shakyas, the male Vajracharyas being the only ones entitled to be domestic priests, the menfolk of the two groups together providing the temple priests of the Newar Buddhist *viharas*. Thus Vajracharyas and

Shakyas are in practice part-time monks. They are householders (*grhasthi*, *gristi*) and pass on their sacred statuses patrilineally. Vajracharyas and Shakyas may and do intermarry, but there is a slight preference for endogamy; thus, effectively, they form a single caste with two ranked sub-sections with different socio-religious identities (Gellner 1995). While carrying out their religious roles they adopt the position of monks: thus Vajracharyas fast and maintain strict purity rules while carrying out domestic rituals for Buddhist Newars; both Vajracharyas and Shakyas, while carrying out the role of temple priests in a *vihara* adopt the dress and rules of monks, with a monastic robe and eating only one full meal a day.² In the past, most members of the caste earned their living as artisans, especially as goldsmiths, silversmiths, coppersmiths, carpenters, god-casters, and so on. A few became rich traders while in Tibet.

The term for monk in this traditional form of Buddhism was *bare*, derived ultimately from the Sanskrit *vandya* or 'venerable'. In Nepal Bhasha the word refers primarily to the Shakyas as a caste, though it is also used by many to refer to Vajracharyas and Shakyas together (Gellner 1992: 67). Shakyas and Vajracharyas do not themselves like the term, because it is used in a non-honorific and, they believe, insulting way by the high-caste Hindu Shresthas, and therefore they avoid its use as much as possible. It is, however, an unavoidable part of certain set expressions, and in particular of *bare chuyegu*, the primary name for the ritual of initiation by which a Shakya or a Vajracharya boy becomes a member of his father's monastery. *Bare chuyegu* means, literally, 'becoming a monk'. Euphemistically the ritual is often called *cudakarma* or 'tonsure'. The texts call the ritual *bhiksu-pravrajya* or 'renunciation as a monk'. During this ritual the boy spends four days as a monk and on the last day he goes through a rite called 'laying down the robe' (*civar kwakayegu*) in which the boy's domestic priest reads out a recitation, on the boy's behalf, in which he is supposed to say, 'The [monastic] path of the Shravakayana is too hard for me to follow permanently. Please show me an alternative.' To this priest responds by initiating the boy into the Mahayana and Vajrayana paths of Buddhism.³ The ten or five most senior members of a Newar Buddhist *vihara* are known as 'elders' (*sthavira*) and they carry out the most important regular rituals. Colloquially they are called *aju*, i.e. 'grandfathers'.

Although Vajracharyas and Shakyas carry out these rituals of monasticism in a number of contexts, they only form a small part of their overall religious practice. The highest salvific practice is to take Tantric Initiation, a secret ritual that lasts many days and is ideally taken with one's sexual partner. It involves following practices that are in direct contravention of monastic codes: the ritualized and sacramental consumption of meat and alcohol, sacred dance performed by the initiators, and possession (Gellner 1992: 266ff.). The divine representations of the highest Buddhist path show Tantric Buddhas in full sexual intercourse. But, and this is a key point, these divinities were displayed traditionally only inside shrines to which access was restricted to the initiated. The way in which they can now be seen on sale to tourists and in shop windows throughout the city is a flagrant breach of traditional conventions. No one who had not taken the requisite initiations was supposed to see or know about them. Consequently, the more ascetic and monastic values of the religion – though not the actual practice of monasticism – were a large part of the public face of traditional Newar Buddhism (though the Vajracharya priests' predilection for alcohol was also a stereotype of popular culture).

In short, monasticism within Newar Buddhism was restricted to certain public contexts, it was primarily symbolic, and the high status of those allowed to enact it was passed on patrilineally. Monkhood was indeed all in the family (and caste). Monasticism was a key legitimating symbol, but even the most learned and ascetic of Newar Buddhist practitioners were not, at least not primarily, monks. They inherited their position as Buddhist priests and – one or two very rare exceptions apart – they did not withdraw from family life, but rather depended on it for their religious privileges. Vajracharyas' position was legitimated by their status as guardians of the Tantric Buddhist (Vajrayana) path; Shakyas were traditionally mostly known either as Shakyabhikshu ('Buddhist monk') or as Shakyavamsha ('of the Buddha's lineage'), and, apart from the fact that they filled the local role of Buddhist monks, it was indeed as kinsmen of the Buddha that they found their deepest legitimation.⁴

Newar Buddhism has always existed in contact with Tibetan Buddhism (Lewis 1989). Centuries ago Tibetans came to the Kathmandu Valley in search of Buddhist teachings. They continued to come on

pilgrimage to the Buddhist holy sites of Nepal, principally Swayambhu, Baudha, Namobuddha, Lumbini, and the Buddhist shrines of the Valley cities of Kathmandu, Lalitpur and Bhaktapur. Some followers of Tibetan Buddhism, usually Tamangs by ethnicity, have always lived inside and around the rim of the Kathmandu Valley. Occasionally, even before the twentieth century, Newars took ordination as a Tibetan monk. Newar Buddhists recognized Tibetan Buddhism as a form of their own Tantric Buddhism, with the same divinities and practices, even if the institution of incarnate lamas was unique to Tibet. Theravada Buddhism, on the other hand, was unknown to them and it was only in the 1930s that they became acquainted with it for the first time.

Among Newars of the Kathmandu Valley today there are still some households where there is a preference for Tibetan Buddhism, in which the pious members of the family (usually the elders) say their prayers in Tibetan. There are many more where they have gone over to Theravada Buddhism and where devotions are carried out in Pali, the language of the Theravada scriptures, and these include many more young people. Such households – whether pro-Tibetan Buddhism or pro-Theravada – do not usually cut themselves off from their Newar Buddhist heritage. They still continue to call their Vajracharya priest for necessary life-cycle rituals. But their optional religious observances will be carried out in another idiom and using other specialists.

There is then a co-existence in contemporary Newar society of (a) Vajracharya priests; (b) the Vajracharya and Shakya caste, who traditionally claim to be ‘married monks’ but are now almost entirely secularized and embarrassed by the claim to sacerdotal status (and even practising Vajracharya priests nowadays dress like laymen most of the time), (c) Theravada monks and nuns who practise celibacy, and (d), on the fringes, Tibetan lamas, some of whom are members of celibate orders, while others are married. The Theravada monks and nuns disparage traditional Newar Buddhism, saying that it is not real Buddhism, and criticizing its ritualism, its connections to animal sacrifice, and the Vajracharyas’ use of alcohol. The Vajracharya priests, for their part, regard monks as selfish, receiving the alms of the laity and giving nothing in return. Some Theravada monastics inhabit what used to be Newar Buddhist religious sites, having been given small, decrepit or

abandoned *baha* to occupy. None the less, architecturally and iconographically, the various Buddhist traditions are as easy to distinguish from each other as they are sartorially or liturgically. Theravada *viharas* are usually modern, functional cement buildings painted yellow. In a few cases, munificent (usually foreign) donations have transformed them into marble-paved halls, or, as in Kirtipur, into a gigantic and highly visible simulacrum of a Thai temple. The *baha* of traditional Newar Buddhism, on the other hand, are usually situated around a courtyard set back from the road, with characteristic carved wooden tympani over the doors of the shrines, carved wooden struts supporting a tiled roof, and at least one, and often numerous, *caityas* adorning the courtyard in front.⁵

The introduction of the Theravada movement has opened up leading Buddhist religious roles to men and women of all castes and backgrounds, where previously they were restricted to Vajracharya, and to a lesser extent Shakya, men. The emergence of new roles for women is a remarkable innovation, for which the women have had to struggle for fifty years. Since the Theravada monastics (unlike Vajracharya priests) may not work (except at teaching), they almost never have salaried employment and rely on the laity to support them. This means that a series of overlapping lay communities supporting the monastics and focused on specific *viharas* has grown up, which re-creates – in a more modern, less caste-bound, and more open and fluid way – the communal focus that existed, and still to some extent does exist for their members, in the traditional Newar Buddhist *bahas*. Traditional *bahas* belong to, and have as members, the male members of one, several, or (in the case of a few large ones) a large number of Vajracharya and Shakya patriline. The Theravada *viharas* belong to (are donated to) the Sangha or monastic association, of Nepal, and are run by self-chosen committees of lay people. These lay people may be related to each other but there is no requirement for them to be so.

The Beginnings of Theravada Buddhism in Nepal

Given this background, it is perhaps understandable that Shakyas and Vajracharyas should be predisposed to be impressed by the Buddhism they encountered in Tibet; it also made good commercial sense as well to

seek the protection of powerful Buddhist institutions in Lhasa and elsewhere. Then, in the 1920s, there was an upsurge of Buddhist revivalism in the Kathmandu Valley itself. A number of factors seem to have come together to produce this revival. Pandit Nisthananda Vajracharya of Kathmandu went to Calcutta in 1914 in order to have his Nepal Bhasha (Newari) version of the Buddha's life-story, the *Lalitavistara*, printed. Both before and after the printing he held numerous public readings of it. A group from Uku Baha, Lalitpur, were inspired by this to put on a play of the Buddha's life, which was widely influential. Dharma Aditya Dharmacharya, born Jagat Man Vaidya, went to Calcutta to study commerce, came under the influence of Anagarika Dharmapala and his Maha Bodhi Society, and was attempting to revive Newar Buddhism by various modernist activities, such as publishing Buddhist magazines, founding new organizations, and holding conferences. In 1925 a charismatic Tibetan celibate, Kyantse Lama, came to Kathmandu and gave teachings to which hundreds of Newar Buddhist devotees flocked. Under the influence of all this five young Newar men became monks in the Tibetan tradition. By caste they were three Shakyas, a Manandhar, and a Shrestha. The last was Mahapragya, destined to become one of the most influential Nepali monks. Because Mahapragya was a Shrestha, and therefore presumed to be born a Hindu, the Rana authorities took umbrage and expelled all five plus the lama who had initiated them to India. There they made contact with the Maha Bodhi Society and Theravada Buddhism, though they did not convert immediately. Mahapragya continued to Tibet, and in Lhasa he recruited a young Newar trader, an Uday, who became Karmasil (later Pragyanaanda). Together they performed austerities, but unconvinced, they returned to India. In successive years, 1929 and 1930, they went to Kushinagara, where the Buddha died and attained ultimate enlightenment, and took ordination as Theravada novices from the Ven. Chandramani, a Burmese monk who had been sent to Kushinagara at the instigation of the Maha Bodhi Society.

It is an important and interesting question why they chose to give up being monks in the Tibetan tradition. The evidence, at least for these early founders of the Theravada movement, is that they did not see any fundamental difference between Theravada Buddhism and Tibetan Buddhism. What was important was to be a monk and thus to reintroduce

permanent monastic practice to the Buddhism of the Kathmandu Valley. They became persuaded that Pali was easier to learn for Nepalis than Tibetan and that Theravada Buddhism was easier to study and teach than Tibetan Buddhism.⁶ The position of female converts was different, because the Theravada nuns' ordination lineage had disappeared from South Asia in the eleventh century and had never been revived. Thus, the nuns, unlike the monks, were stepping into a hitherto almost unknown role. As the tradition had died out, and because it takes a minimum of five nuns to ordain a new nun, they could not have the status of a fully ordained nun or *bhikkhuni*. Thus they were merely ten-precept laywomen or *anagarika* (homeless ones).

The young religious reformers of the 1920s-1940s sought to *reform* Newar Buddhism, rather than *replace* it, and to do so by reintroducing to Nepal the genuine monasticism which had metamorphosed into a caste of householder priests in the Middle Ages. They also sought to rid Newar Buddhist traditions of what they saw as un-Buddhist practices, especially animal sacrifice, adopted from the dominant Hindu culture, and they sought to educate the laity about the dharma and provide them with vernacular translations of canonical texts. They encouraged devotions focused on Sakyamuni Buddha rather than on the traditional elaborate Hindu-Buddhist pantheon of gods and bodhisattvas.

Several of the new Theravada monks had once been married but had left their families 'to go into homelessness'. All the nuns were formerly-married women seeking to escape the social marginality of widowhood or divorce. For many years their only recourse was to share quarters with the monks who repeatedly obstructed their relationships with the laity and expected them to fill the role of monastery servants.

From perilous beginnings in which they were harassed, imprisoned, and even exiled by the brahmanically orthodox Rana government, the Theravadins saw their revival movement slowly gain momentum, particularly after the Rana regime was ousted in 1950/51. By the mid 1970s, forty years after the first Theravadin monks preached the dharma in Nepal, there were 44 monks and 37 nuns; by the end of the 1980s there were 59 monks, 72 novices, and 70 nuns, and in 2001, 78 monks, 94 novices, and 118 nuns. Where there had been no Theravada monasteries in Nepal in 1930, today there are 98, including 17 nunneries.⁷

Although almost all Newar Buddhist still call Mahayana priests to perform domestic life-cycle rituals, they often do so in the most minimal way compatible with their social status. The Theravada Buddhists have succeeded in almost wiping out one traditional ritual and replacing it with one of their own devising. This is the traditional *barha tayegu* puberty ritual for Newar girls, for which now the vast majority of Buddhists substitute *rishini pabbajja* ('the renunciation of a sage-ess'), sending their daughter to a Theravada *vihara* for between three and twelve days of instruction in Pali and Buddhist precepts. What the Theravadins have succeeded in doing in the case of this one ritual they may eventually succeed in doing in others as well. Even if they do not, ideologically many prefer Theravada Buddhism which, being more comprehensible, egalitarian, and inclusive of women, they see as better suited to modern life.

The Theravada monks are called *bhikshu*, and their presence in the Kathmandu Valley has more or less effaced the Shakyas' and Vajracharyas' claims to be the monks of Newar Buddhism. No Shakya today uses 'Shakyabhikshu' ('Buddhist monk') as his surname. Lay people address Theravada monks using the newly introduced term *bhante* (Pali 'venerable') and this word is often used colloquially in reference to mean 'monk' and in the plural to mean 'monks'. Very senior Theravada monks are called *sthavira*, 'elder', just like the elders of a traditional Newar Buddhist monastery; but no one would use the colloquial *aju* (grandfather) for a Theravada monk. Between themselves monks do use kinship terms for address; thus a very old monk will be addressed as 'Bhante grandfather (*bhante bajya*)'. This use of kin terms as a respectful way to address unrelated seniors is carried over directly from Nepali and Nepal Bhasha. A slightly older monk may be addressed as 'Bhante older brother (*bhante dai*)'. Younger monks are normally addressed by name. More formally the Pali word *avuso* or *ayusman* ('friend'), either on its own or with their name, may be used.

For female monastics the situation is more complicated. The nuns' Order had died out in Theravada Buddhism, so technically renunciate women could not lay claim to the status of full nuns (*bhikkhuni*) and were only 'ten precept laywomen', for whom the new word *anagarika* or 'homeless one' was adopted from the 1930s. In the 1980s a movement,

led by Western feminist Buddhist, started for the re-establishment of the nuns Order where it had died out and its establishment where it had never existed (e.g. in Tibet). The older Theravada monks in Nepal follow the monastic establishments in Burma, Thailand, and Sri Lanka, in rejecting the possibility of re-founding the nuns' Order and therefore refuse to refer to contemporary nuns as *bhikkhuni* (Pali) or *bhikshuni* (Sanskrit), or to their nunneries as *vihara*. Instead they continue to call them *anagarika*. Colloquially the problem is avoided, because the most common way to address nuns, and to speak about them in reference, is as *guruma* ('guru mother'), the term that was and is used for the wife of a Vajracharya priest, who accompanies her husband to domestic rituals as a kind of assistant.⁸

Caste in Newar Buddhism

Sakyamuni Buddha established a monastic order based on a hierarchy of ordination rather than of caste and accepted recruits from many backgrounds, including untouchables. In this regard the egalitarianism of the early Sangha contrasted sharply with the hierarchical structure of South Asian society in which it was embedded and in which the Buddhist laity, like Hindus, was ordered by caste. Although we can only speculate about the structure of society in the Kathmandu Valley before the common era, inscriptional evidence from the Licchavi period (fifth to tenth century CE) indicates that a caste society similar to that of the Indian plains had developed. By the fourteenth century, when the Sangha is thought to have completed its long process of laicization, it came to occupy the summit of a baroque and complex caste system. At its apex stood two householder priestly castes: on the one side the Vajracharyas and Shakyas, on the other side Hindu Brahmans. Although far more numerous than the Brahmans, the Vajracharyas, in particular, were, and were seen as, the Buddhist equivalent of Brahmans. Below them in the hierarchy of purity/impurity came five more 'blocs' of castes: (i) traders and landowners (Shresthas, mostly Hindu, and Uday, Buddhist); (ii) farmers (Maharjan-Jyapu, in the west of the Valley Buddhist, in the east mainly Hindu); (iii) many small 'clean' occupational (artisan) castes (mostly Buddhist); (iv) the Butcher/Milkseller caste, theoretically not untouchable though water was not supposed to be taken from them; (v) Untouchables, mainly Sweepers.⁹ Shresthas and Udays as well as

Vajracharyas and Shakyas were eligible to take Tantric initiations which enabled them to participate in salvific rituals from which members of lower castes were excluded. Although upper-caste wives took such initiations along with their husbands and the wives of Vajracharyas took supportive parts in ritual practice, the great majority of Buddhist women, excluded from religious instruction, were confined to a devotional role.

The first small group of Newars who took Theravada ordination came almost exclusively from upper-caste and Buddhist backgrounds. With the exception of Mahapragya, who was a Shrestha, all male as well as female monastics were either Shakyas, Udays, or Manandhars.¹⁰ As occasional temple priests but not domestic priests, Shakyas were barred from making a livelihood by performing rituals for the laity; instead they worked as goldsmiths and icon makers. The traditional identity of Shakyas as 'sons of the Buddha', 'descendants of the Buddha' (Shakyavamsha), and Buddhist monks (Shakya-bhikshu) in a ritual sense, if not in actual life conduct, meant that Shakyas were particularly likely to feel the call of monasticism. For an example of the way in which Theravada adherence tends to cluster in related households, see Figure 1.

Figure 1: A Shakya Lineage and its Theravada Attachments

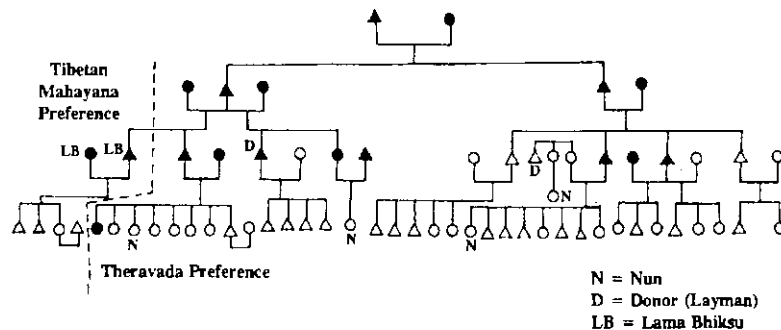

The Udays meanwhile had recently become embroiled with their Vajracharya priests in a long-running and bitter dispute over relative

caste status, which meant that they were very open to criticisms of the Vajracharya's version of Buddhism (Rosser 1966). In the movement's early years the small group of donors on whom the Sangha depended for financial support was composed of rich merchants and businessmen from the same upper-caste background as the monks and nuns.

Monastics and inheritance

At ordination monastics shave their heads, exchange lay dress for monastic robes, take up their begging bowls, and go 'into homelessness'. However, as Gregory Schopen's studies of the *Mulasarvastivada Vinaya* have shown, monks in medieval north India were not required to renounce private wealth at ordination; rather, they were expected to retain it, to use it wisely, and to bequeath it to the Sangha at their death (Schopen 2004: 3-4, 13-14). Indeed, monastic status and reputation were closely related to wealth. While the source of funds is never indicated, Barnes' study of donative inscriptions dating from the second century before to the third century after the beginning of the common era shows that nuns and well as monks were making substantial gifts to stupas (Barnes 2000: 21). Although donations from devotees may have been a more ample source of their wealth, inheritances received from parents and other members of the family of origin both prior to and following ordination were viewed as legitimate and not uncommon (Schopen 2004: 102).

With the exception of two who, before they renounced the world, had been involved in the Lhasa trade, monks in the first cohort of Newar Theravadins had no personal resources to speak of when they joined the Order and thereafter were dependent on donations from their lay followers. A few monks lived long enough to accumulate wealth and property through donations; but although, under the Nepal Law Code, they were also entitled to inherit a share of their father's property equal to that of their brothers, since most were from poor families, in practice they renounced their rights to paternal property. The same is true today. A monk in his late twenties named Suman ordained as a novice at age 14, shortly after the death of his father, was intending – albeit unofficially – to renounce his patrimony. More recently, he thought seriously about leaving the Order but in the end, as he told us, decided to remain a monk

because he realized that, at this late date, to ask his brother to give him half their father's property, a small piece of agricultural land in an outlying village, would be "the most painful thing I can imagine".

Prior to a change in the inheritance law in 1975, only daughters who had no brothers could inherit parental property, and even then it helped to remain unmarried. A daughter with brothers had no further claim on parental property after she got married and received a dowry (*stridan*) of gold jewelry, clothing, and household requisites. As childless widows and divorcees, most nuns in the first cohort were at least as impoverished as the monks. An exception was Vasaka, a divorcée who, because she had no brothers, had inherited her father's property, drew on personal resources to help her co-religionists and to travel abroad, in addition to supporting herself in the substantial house she had inherited (S.M. Tuladhar 1993). There is no evidence that the childless widow Dharmachari, who from the 1930s until the mid 1960s was the leading nun in Nepal, inherited money or property from her own or her husband's family; never the less, because she attracted many devotees from the well-to-do merchant community to which she belonged, in the late 1940s she was able, with their donations, to build the first nunnery in Nepal, in which, once they were living independently, the nuns largely evaded the monks' control.

The 1975 law gave daughters who reached the age of 35 without getting married an equal share of their father's property. In theory it should have had a major impact on the nuns, especially those who came from wealthy families; in practice, however, the only nuns who actually claimed their inheritance were those who had no brothers. As a nun named Dhammasevi, an only daughter who had two brothers, told us in 1997, "I'm not going to ask for anything." If she did, she explained, she would antagonize her sisters-in-law. "If my brothers decide to give me a share, I'll accept it, but it's up to them." In 2001, the law was changed to allow all adult unmarried daughters (aged 18 and over) equal property rights to those of their brothers. However, if, after receiving her inheritance (either following a property division while her father was still alive or after his death), a daughter married she was required to return to her brothers whatever remained. To date we have not heard that any nuns have tried to take advantage of the new law. As a senior nun from a

wealthy family told us in 2004, customs are more important than laws. She would continue to depend on the generosity of her three businessman brothers. "If they give to me voluntarily, that's fine," she explained, "but if I pushed them, that would cause problems with my sisters-in-law, and I might end up with nothing." This seems to be the consensus.

Motivations for entering the Order

The first generation of monks and nuns shared a reforming zeal and a desire to study the dharma and to teach it to others. All saw ordination as an escape from normative adult roles. The monks, whether married or single, were looking for a haven from householder life while the nuns, all of whom had once been married, were in flight from the social marginality of widowhood and divorce. Life in Kimdo Baha, the ancient Newar Buddhist monastery that a rich merchant had restored and where the majority lived throughout the 1930s and most of the 1940s, was not easy, especially for the nuns, who, since the laity viewed them as lesser 'fields of merit', received many fewer donations than the monks; but at least there was time for religious devotions and teaching the fundamentals of Buddhist belief and practice to lay people who sought them out. Most of the monks, with the help of the Mahabodhi Society, were able to travel abroad to study in Burmese or Sri Lankan monasteries, opportunities which were denied the nuns until many years later (Kloppenborg 1977).

In the 1950s, after a century of isolation, Nepal started to open up. Western schooling, until now confined to a small elite in the Kathmandu Valley, began to spread throughout the country. A trickle of development aid became a flood, communications improved, tourists arrived in ever increasing numbers, the towns began to grow and develop rapidly, so that the gap between town and countryside became ever wider and harder to bridge, and a new middle class emerged defined by new consumption patterns (Liechty 2003). Since in pre-modern Nepal the higher castes were by definition more advantaged, when society started to modernize they were best-placed to seize on new opportunities and to win the lion's share of political and professional positions. The structural inequalities that were revealed by census figures in the 1990s became a serious political issue and have been frequently invoked to explain the success of

the Maoist movement in attracting the poor, the female, the low caste, and the Janajatis.

The consequence of these social changes for Theravada Buddhism was that young men from upper-caste families, faced with a variety of education and career options, found the idea of studying Buddhism for a decade in a monastery in Mandalay much less attractive than securing a well-paid position with an INGO after studying on a scholarship in Germany, China, or the US, exporting curios to East Asia, or opening up a tourist hotel. Celibacy, in itself an alien if not bizarre concept in a community that had had no monks for hundreds of years, was the main drawback to monasticism. Even though an adolescent boy might be too shy to articulate his objections, his parents most definitely could articulate theirs: they believed that a man should marry and have children, care for his parents in their old age and perform their funerary rites at their deaths and from then on until he himself passed away. As religious virtuosi, monks were to be admired, venerated, and supported financially, but they should by preference be other people's sons.

Thus, by the 1970s, unless his family was too poor to educate him past primary school, monasticism had ceased to be a desirable or even acceptable career for boys from upper-caste Buddhist families. Although the most senior monks, all of whom had entered the Order in Rana times, were from upper-caste backgrounds, Hartmann (1993) showed that by the 1980s novices (*samanera*) were being drawn almost exclusively from impoverished rural families belonging to farming or lower (but clean) castes. Their parents, in contrast with Shakya and Uday parents, encouraged ordination because, in the short run, by 'giving a son to the vihara' they stood to earn prestige in their community as well as spiritual merit. In the long run, since the culture of *aphno manche* ('one's own person', i.e. person who is either kin or an old contact) prevailed in the monastery as well as in lay life, as he proceeded up the monastic ladder a monk was expected to help his kin and those with whom he had long-term ties whenever possible. In Nepal, as in Sri Lanka, ordination is preferably a life-long commitment, but it does not have to be. Increasingly the Burmese and Thai ritual of temporary ordination has gained currency, and with it the South-East Asian presumption that there is nothing wrong with a man leaving off being a monk. This notion has

been taken advantage of by young Nepalis and their families. When a young monk reaches adulthood – provided he is willing to face the disappointment of his community who had invested in his training – he can disrobe, take the conventional path of marriage and fatherhood and – with the credentials and language skills acquired abroad – get a good job and contribute to the economy of the joint family.

Although, as before, widows and divorcees continued 'to come to the vihara', in the 1940s the nuns' Order began recruiting young single women, some of whom, like the novice monks, were village girls from Jyapu families. Meanwhile upper-caste girls were continuing to ordain. The most prominent nun in Nepal today is Dhammawati, daughter of a Shakya goldsmith from Lalitpur, who aged fifteen ran away from home to become a nun; after studying for thirteen years in Burma, she returned to Nepal in 1963 resolved to teach Buddhism to people of all ages and most especially to women. Although she inherited nothing from her father (who had bitterly opposed her becoming a nun), two of her brothers gave her part of their inheritance to buy land in old Kathmandu on which, with donations from her devotees (who included her mother), she built Dharmakirti Vihara, to which flocked many prominent merchants as well as Buddhist women of all ages. In 1988 she and two companions took full *bhikshuni* ordination according to Chinese rites at Hsi Lai monastery in California. Since then, defying the interdiction of the senior monks, one third of Nepali nuns have followed their lead.

Over four decades Dhammawati's intelligence, courage, and energy have attracted many young women who, like herself, are from upper-caste, even privileged, backgrounds. By the 1960s, when very few girls were as yet in school, several recruits had attended secondary school; by the 1980s a few were university graduates; and in the 1990s two devotees with Master's degrees abandoned successful careers in government service to ordain as Buddhist nuns while two others, with family support, went on to receive PhDs. Of 75 nuns resident in the Valley in 1999, 45 (60%) were upper-caste (Vajracharya, Shakya, Uday, and Shrestha), 22 (29.5%) were Jyapus, 4 (5.3%) were from non-Newar Janajati ethnic groups, and 4 (5.3%) were Manandhars, members of the Newar Oil-Presser caste. While a few Shakya nuns were from impoverished backgrounds, the majority were well-to-do. Again, although some Jyapu

nuns were also from poor families the majority were comfortably off. Coming from families who believed that educating daughters was as important as educating sons, most of these nuns – unlike the monks – came to the vihara with credentials in hand.

As with Bartholomeusz's Sri Lankan *dasa sil mata* informants (Bartholomeusz 1994), the primary objective that all recruits to the nuns' Order shared was to avoid marriage. For Newar women, marriage normally requires 'going to live in the house of a stranger' followed by many years of subordination to mothers-in-law and husband's elder brothers' wives while, provided they bore sons, their status in the household hierarchy slowly improved. Far from being a harsh deprivation, these young women viewed the celibacy that their ordination vows imposed as an incomparable blessing. Instead of a 'renunciation', they saw ordination as an 'emancipation' from the restraints of householder life: they could study and teach the dharma, meditate, travel, pursue religious studies in nunneries abroad, translate and edit texts, and, through their work as ritualists and counselors, earn the affection, admiration, and respect of the laity. Not all Newar women get married but even today a single professional woman of good family would not consider living alone. Those who remain single, whether by choice or because a suitable match has not been found for them, have to stay in their natal homes, where there is almost inevitably tension with their brothers' wives. Thus one important long-term advantage that the Order has to offer is that, instead of being dependent on resentful in-laws, elderly nuns can live in the nunnery, where they will be cared for by younger nuns, their *cheli*, whom they themselves have trained.

Although over the seventy-odd years since Theravada Buddhism came to Nepal many more men than women have taken ordination, a large proportion – possibly half – of the monks have eventually disrobed. Latterly, many have chosen to settle down in the Buddhist countries where they have received their education since their credentials and their status as former monks have more purchase there. By contrast, having 'shaved their heads', few nuns have left the Sangha. In their decision to ordain, many met with intense opposition from their families which, since parental consent is required, often took months if not years to overcome. Parents view arranging good marriages for their children of

both sexes as their most important spiritual, as well as social, responsibility and frustration in this regard as a personal tragedy. But once having consented to her ordination, most give their wholehearted support to their daughter's monastic career. Rather than losing her to another family as they would if she were to have married, they keep her, as it were, and at the same time they, as well as she, earn prestige and merit to which, as they support her projects in the nunnery, they add over the years. In such a case, just as in traditional Newar Buddhism, though even more narrowly, merit and wealth are circulated within the family.

HELPING THE FAMILY

1. Opening doors

Monks and nuns are expected to help their family members in various ways, in particular by arranging for the admission of young relatives to the Order. This requires finding a senior monk or nun with the resources to provide for the daily needs and education of the novice or young nun. In the early years the Theravadins made up a small disparate group of individuals each of whom was taking a leap into the unknown. Even so, several were related to each other, as were the devotees who supported them. At least some kin could always be relied on if all else failed. Although the lay community is now much larger, it remains tightly knit through kinship and friendship, and so does the Sangha. Of seventeen nuns living in Dharmakirti in 1999, the majority had grown up in Theravada families; eight had sisters or first cousins who were nuns and four had brothers who were monks.

Most recruits today come from Theravada families. Aside from a few who belong to Janajati groups and grew up in remote areas which monastics rarely visit, most have known and even been close to monks and nuns from an early age. As small children, they accompanied their mothers to the vihara; they saw monks and nuns come to chant, teach, counsel, and receive the midday meal (*bhojana dana*) in their homes; when they reached primary school age they started to receive religious instruction in the vihara and many took temporary (ten-day) ordination there as well. Once they have made the decision to take the precepts (or their parents have made the decision for them), if they have relatives in

the Sangha, the parents' next step is to ask them to intervene with a senior monk or nun on their child's behalf.

A monk named Dipaka, the eldest of four sons of poor parents, ordained as a novice soon after the death of his father and was sent by his preceptor to study abroad. Within a few years he was able to place two of his younger brothers in a Kathmandu monastery, leaving only one brother to take care of their widowed mother. But his responsibilities for his siblings did not end there: last year he arranged for one of his brothers, a recent secondary school graduate, to enter an Australian monastery; now he is looking around for a foreign Buddhist institution willing to take his other brother.

A nun named Padmawati recalled that when a cousin's husband died leaving several young children, her cousin begged her to take the eldest, a girl named Ratna, who at the time was nine years old. Padmawati, who was only about twenty, was in no position to do so because she did not have the resources to care for the child. As a young nun, the lay people viewed her as a poor field of merit; thus she received little *dana*, barely enough to cover her personal expenses. But through her good offices, her abbess, Dhammawati, accepted the child and for the last twenty years has provided for her education, just as she has for several other fatherless girls whom family members, as a last resort, have 'brought to the vihara'. Today Ratna has a university degree, and after spending extended periods of time in Fo Kuang Shan monasteries in Taiwan and California where Dhammawati had contacts, speaks good Chinese and English. Meanwhile Padmawati has herself become an abbess. Thus when her brother-in-law died a few years ago and her widowed sister asked her to take in one of her daughters, she was able to do so. Soon after giving the girl the precepts in an elaborate ceremony which she paid for, Padmawati found a place for her in a Burmese nunnery whose abbess was a close friend. When, after some time, her niece became dissatisfied with the education she was receiving – she wanted to learn English – Padmawati again used her foreign contacts to secure a place for the girl in a Sri Lankan nunnery school which featured English in its curriculum.

Nuns sometimes make arrangements for young male relatives and vice versa. A monk named Kosala tells how, as a young boy growing up in a village in the Kathmandu Valley, he would visit his aunt, who was

one of the first Jyapu women to ordain, in the Lalitpur nunnery where she was living. When, some time later, he began to show an interest in the dharma, she arranged for him to live in the next door monastery, where he became the abbot's servant; he eventually took novice ordination there and, thirty years later, is now its abbot himself. About ten years ago he ordained his father who, he says, "had been waiting to come" for a very long time; the old man now lives in the next room. His mother would like to ordain as well, says Kosala, "and my father and I would be happy to give our consent. But my brothers won't give theirs," he adds sadly, "and without it, she can't leave home."

Another Jyapu monk who had grown up in Bhaktapur but has been studying in Thailand for many years, learned that his sister, whom he scarcely knew, since she was born after he left home to become a monk, was deeply unhappy living with a relative after both their parents died. He was able to secure a place for the girl in a nunnery outside Bangkok, find sponsors willing to support her stay, and raise the money for her airfare as well. When, after a few months 'trial' in the nunnery, she asked to take the precepts, he paid for her *pabbajja* (ordination ceremony) himself.

2. Arranging for medical care in foreign hospitals

Given the poor state of medical care in Nepal, anyone who can afford to do so prefers to be treated abroad. Vellore (in south India), Delhi, Singapore, and Bangkok are the favoured destinations. In fact, Nepali monks stationed in Bangkok can find a very large amount of their time being taken up with accompanying visitors from Nepal to hospitals, shopping malls, and Thai holy sites. Almost all the monks and some of the nuns have spent long periods studying abroad and since many speak local languages as well as English and are familiar with foreign medical systems, they are called upon to arrange treatment for sick relatives as well as members of the lay community generally. Whereas nuns, whose families are often rather well off, are 'only' required to organize the treatment process and stay in hospital with the patient, monks, whose families are of much more modest means, must also raise the funds to cover the considerable expenses involved. Provided they are senior enough, they do this from donations that in the usual course of events they receive from the laity.

3. Caring for elderly parents

Zangskari nuns are required by their families to perform many domestic tasks from caring for young children to working the family fields in return for the life-long economic support without which they and their nunneries could not survive (Gutschow 2004). By contrast Nepali nuns' hands-on responsibilities to their natal families are generally confined to caring for parents. (No Nepali monastic would ever labour, in the fields or anywhere else.) Monks, too, are expected to contribute to their parents' support, but whereas it is enough if they simply give money to the old people themselves, or if they are infirm, to a brother living in the same house, nuns are expected to play a central role, especially in the care of their mothers. Even if there are several daughters-in-law in the household a mother still feels closer to and trusts her daughter more, and, if she is unmarried, she is seen as 'available', regardless of her responsibilities in the nunnery. Thus nuns are frequently called home for indefinite periods not only from local nunneries but from abroad. In Dharmakirti in 1997 three of the seventeen nuns had been called back from their studies in Thailand to care for ailing mothers. Padmawati, who as abbess of Mayadevi Vihara runs a complex operation, dreads the days when her mother falls sick; she knows that, despite having three daughters-in-law, her mother will want her to be at her bedside. The best solution, one that Thai abbesses commonly resort to also (Falk 2000: 44), would be to bring her mother to live in the nunnery. ("But will she be willing to leave her home?" Padmawati wonders. "Probably not...")

4. Building contracts

Senior monks and nuns are frequently engaged in construction projects and need to hire contractors to carry out the work. Although in recent years Dhammawati, a Shakya, and Padmawati, a Manandhar, have carried out ambitious projects, neither has given contracts to relatives. It so happens that neither has relatives in the construction business. By contrast, Kosala, a Jyapu, hired his contractor brother to rebuild the vihara in Lalitpur of which he is abbot, a project which took several years and cost many hundreds of thousands of rupees.

5. Private property

According to the rules promulgated by the Mahasangha, the umbrella organization of the Theravada Monks' Order in Nepal which was established in 1944, a monk is required to register any property, however he may have obtained it, in the name of the Sangha; similarly, he must bequeath all the money he may have accumulated to the Sangha; and after his death his personal possessions are to be distributed among his fellow monks. The nuns, as ten-precept lay women, are excluded from the Mahasangha (thus far the senior monks have refused to acknowledge their fully ordained status) but have adopted similar rules. Each nunnery is supposed to be registered in the name of its management committee, which includes lay people as well as monastics, and bank accounts should be registered in the same way. The basic rule is that all monastic property belongs to the committee, which, at the death of the abbess, will be charged with finding a replacement.

A professional woman who sat on a management committee observed that even their treasurer, a man with a great deal of experience in business, knew little about the monastery finances. This was because, when making donations, donors distinguished between those that were for the institution, for which they were supposed to receive receipts, and those which were for the personal use of the abbot or abbess. Furthermore, even though monastery accounts underwent an annual government audit, many cash donations were never recorded let alone deposited in a bank account; money came in and was spent and, as our informant told us, "Only the abbot knows where that money went." In short, a situation open to abuse.

Although thus far the nuns have escaped financial scandal, the monks, some of whom have received large sums of money from foreign sources, have not. An early case in point occurred when Amritananda, founding Secretary of the Mahasangha, abbot of Anandakuti Vihar, and for forty years the chief spokesperson for Theravada Buddhism in Nepal, raised funds (including 200,000 rupees from Chou Enlai, whom he visited in Beijing) for a Buddhist school to which he appointed his son-in-law headmaster. With the massive expansion of private schools from the 1980s, its originally Buddhist character has become increasingly irrelevant and it is now a private-for-profit school like any other and the

personal property of Amritananda's daughter (the only child of his early marriage) and son-in-law. Amritananda, however, was never publicly challenged in this regard. Another notorious case occurred more recently when, after his death, it was revealed that a prominent monk with lucrative foreign contacts had registered in his own name a house which a member of the lay community had donated to the institution that he headed; he had also registered in his own name a bank account in which he had deposited substantial amounts of money from foreign donors. By Nepalese law all these assets would pass to the next of kin, in other words, his brother, who also happened to have been his business manager. Delicate negotiations had to be held between the Sangha and the family members in order to avoid costly and embarrassing court action. By contrast, Sudarshan, abbot of Sri Kirti Vihara, was fully aware of these issues of inheritance and was punctilious in making proper arrangements so that when he died his monastery, as well as the money in the various bank accounts set up for different purposes related to its running, passed without incident to the Sangha.

6. Earning merit through endowments and ritual sponsorship

When monks and nuns 'go to the vihara' their families stand to earn prestige by association; but while a monk's family members hope that, through education and contacts with influential people, he will lead the rest of them into the middle class, a nun's family members are more likely to look to her to provide opportunities to earn merit and raise their status in the community. Devout Buddhist parents who would be horrified if their son told them he wanted to ordain may be enchanted at the prospect of a daughter 'shaving her head' and generously support her thereafter. The monasteries are either traditional Newar *baha* which were given by their owners to Theravada monks who renovated them, or, if newly constructed, were built on land donated by devotees. By contrast, Nepali nuns, like Buddhist nuns elsewhere in Asia (Kawanami 2000; Falk 2000; Salgado 2000a, 2000b) and Catholic nuns in medieval Europe and nineteenth-century America (McNamara 1996), are much less likely to receive endowments from the laity. Although a small number of nuns who become widely known for their piety and good works may be able to raise funds to build a nunnery, most are built by wealthy families for their daughters, who then take in other poorer nuns to live with them.

Thus several nunneries in Kathmandu and Lalitpur and one in Pokhara were either constructed by families for their daughters or built by the nuns themselves with inherited funds. Some families may intend, at the death of the abbess, to take back the nunneries they paid for; but meanwhile they sponsor festive meals and ritual events and provide their daughter, sister, or cousin with funds to support recruits from mostly rural backgrounds.

Kamala, the eldest of ten daughters, trained for many years in a Moulmein nunnery in Burma before returning to Kathmandu, where she earned a university degree. After living for some time in Dharmakirti, she developed rheumatoid arthritis. Wanting her at home where it would be easier to care for her, her rich parents built a vihara on their own property, where she lives with five younger nuns whose routine maintenance her family underwrites. Although, as a daughter, Uppalavanna received no inheritance when her father died in the 1960s, after she returned from training in Burma her businessman brothers built her an impressive house in Lalitpur on land they had purchased expressly for that purpose; they topped the attached dharma hall with a replica of the great stupa at Swayambhu. Uppalavanna has brought a succession of young women to live in her vihara while she arranges for places for them to study in nunneries abroad. Meanwhile her whole extended family regularly turns up with beaming faces for ritual events in the vihara, which they also pay for.

The fourth of eight university-educated daughters, Viryawati is the pride of her family. Having ordained after two years in the university, she spent 12 years in Burma, where she earned the Dhammachariya, the highest qualification in the government-sponsored Burmese Buddhist education system, followed by a year's training as a vipassana meditation teacher. On her return to Kathmandu, her family donated a substantial sum for a women's centre which, when it is completed, Viryawati will head; in the meantime she translates for the Burmese monk in residence in the meditation centre where she currently lives, and teaches meditation to adults and elementary Buddhism to children in the Saturday school.

Dhammasangha is a strikingly handsome woman who, when she took the precepts at age 21, already spoke several languages and had completed an MA in Mathematics. She says she's too busy to live in a

vihara; monastic routine would cut into the time she needs for her work in the community. Instead, she lives in her own quarters at the back of the parental mansion in Lalitpur from which, with her brothers' support, she pursues half a dozen educational and scholarly projects.

Unlike these nuns, all of whom are from wealthy upper-caste urban Theravada families, Padmawati, abbess of Mayadevi Vihar, a nunnery on the outskirts of Kathmandu, is a Manandhar from a town outside the Valley who aged eleven ran away from home to become a nun when she discovered that her father was intending to marry her off. She recalls that it took her at least a decade to persuade her parents, who though well-to-do were traditionalist, that, as she puts it, "Theravada is better than Vajrayana". But ever since she won them over, her family, including several cousins, have been generous with their time as well as their money. She explains that because she doesn't belong to the wealthy Shakya/Uday community of Kathmandu, building a circle of donors among the Jyapus living near her nunnery is a slow business and she is much more dependent on her family than she would like. Her parents have contributed a large part of the construction costs of her vihara, an ever-expanding project whose end is not yet in sight. One cousin provided plumbing fixtures for six bathrooms; another cousin gave her a car and taught her how to drive it; two brothers sit on the vihara management committee; another brother helps with the vihara magazine; her sisters-in-law are kind to the adolescent nuns in her care and efficiently supervise the kitchen where meals for several hundred people are produced on festival days; and at least one relative almost always stays overnight to provide adult company in what might otherwise be a lonely, albeit increasingly high-profile, life. In short, Padmawati's family has embraced her institution-building project as their own; in this life they bask in her reflected glory while earning merit for a good rebirth in the next.

Conclusions

For Newar women from Buddhist backgrounds, renunciation as a nun today is not such a great challenge to kinship norms: (a) because it is not so unusual to be unmarried; (b) because, despite the rise in female employment, there is still little expectation from a daughter's future

earning power (it is assumed that it will accrue to her husband's family if to anyone), whereas sons are looked on as one's security in old age; (c) because, in the ways described, women who become nuns are not really lost to the family, but come to be seen as a valuable source of merit, a way to keep religious activity all in the family. Even in those much rarer cases of women from Hindu backgrounds becoming Theravada nuns, the families do not seem to find the adjustment as stressful as they certainly would in the case of a son.

By contrast, men who renounce are a loss to the family. Where there are many sons it may be a loss that can be borne and which may eventually turn out to have been a valuable investment. But where (as is increasingly the case) there are only one or two sons, the break with family norms and expectations is often very painful. And when it is also the case that the young man in question comes from a Hindu background, so that there is no feeling of merit gained and, on the contrary, the possible negative spiritual consequence of a son lost, in addition to the economic aspect, the parents sometimes cannot reconcile themselves to what has happened and continually urge their child to abandon being a monk and return home. The fact that this is known to be possible and to attract no blame in Thailand and Burma does not make it any easier for the monk.

At the start, the first monks had to be brave and willing to fight against the conventions and expectations of their society (and before 1951 against the very political powers as well). They seized upon the symbols of Buddhist renunciation within the traditional Buddhism of the Kathmandu Valley and infused them with new life and new meaning. In the process they broke the link between monasticism and patrilineal inheritance, a radical act made possible only with the support of their families and extended kin group who were willing to play the role of devoted Buddhist laity.

The women, for whom there was not even the sanctioning role of a symbol within the indigenous tradition, had to innovate even more radically and had to face considerable obloquy and vicious rumours for their pains. At this period the support of family, for those Buddhist monastics who could rely on it, was particularly crucial (when the eight Theravada monks were expelled by the Ranas in 1944, some of the nuns

– whose renunciation was a large part of what had angered the authorities
 – took refuge outside the Valley with relatives in Trishuli Bazaar).

By the time that Theravada was well established, a different set of considerations came into play. Monasticism became a career that some youths could embark upon. But it was not an easy one, as we have discussed, and, especially as society itself became freer, and career options and international links expanded, the rules of the monk's life became increasingly to be experienced as a series of restrictions. By contrast, because of the still greater expectations and restrictions on women's behaviour, becoming a nun was and is experienced as the winning of great freedom, despite the rules that surround being a nun.

Seventy years after the first Theravadins began teaching the dharma in the Nepal, almost all members of that early cohort are dead. But while the charismatic monks of that era have not been replaced and the monks' Order languishes, or at the very least is not as successful as the early founders and activists believed it would be, the nuns' Order flourishes under the leadership of a few dynamic women. True, the monks have built impressive monasteries in Kathmandu, Lalitpur, and Kirtipur in recent decades. The nuns, too, have major projects to their credit in Kathmandu, Lalitpur, and Lumbini. But whereas the abbots built their monasteries largely with foreign funding, the nunneries' construction costs were paid for by local donations. Although some of the senior monks are much admired as scholars and teachers, rumours about their sexual behaviour have long circulated. Donors want to give their money to the purest field of merit and, in that respect, the leading nuns are impeccable. The nuns raised some of the money for their projects by going house to house, but most came through their wide networks: well-to-do family members led the way and friends of the family followed. And the names of the donors whose money helped build those fine dharma halls and dormitories are embedded in the walls where anyone who passes by may read them.

Nevertheless, though successful in its own terms – in building up its support base within the Kathmandu, in reaching out to other ethnic groups and other parts of the country, in recruiting the next generation, and in building international links – the Theravada movement is still much smaller and much less well funded than the various Tibetan

Buddhist sects. The latter, drawing on Tibetan refugees, recruits from enclaves of Tibetan culture throughout the Himalayas. With extensive global links, numerous Western followers and donors (Moran 2004), and a large and rich support base in Taiwan and South-East Asia, Tibetan Buddhists have managed to turn every available hilltop, as well as many other sites, in the Kathmandu Valley into sacred centres of Tibetan Buddhism. One consequence is that in terms of international visibility, Tibetan Buddhism, even within Nepal, overshadows the Theravadins who have been discussed in this paper.

Appendix:

Extracts from Bhikshu Ashwagosh's The Life of a Monk (tr. H.L. Singh)

Taking the present situation into consideration, it appears that even monks must please householders and fulfill their wishes. They must extend helping hands to them. They must give loan to those who come to beg. They are obliged to do other works not at all concerned with Buddhist activities. They have to meet officials and campus chiefs for getting jobs to job seekers or to call the District Judge for settling criminal cases. Besides this, some people do not hesitate to beg money from the monks. They also have to arrange pilgrimages for pleasing the householders. They have to do works not connected with their religious activities. Therefore, it is true that nowadays it is not enough that the monks give sermons and give discourses. They have to do the works of priests (purohit). They have to visit the press for printing books, edit magazines and run organizations. They have to handle money matters in the monastery construction works.

To be involved in construction works shouldering the financial responsibility is not suitable for a monk. Because if for some reason he becomes involved in misappropriated a sum larger than Rs 75, he has committed a parajika, he is defeated, or fallen. It is not only by becoming attached to womankind, getting involved in inappropriate behaviour, and giving birth to offspring that a monk is defeated (parajika).¹¹ The

Buddha had said that avarice is [also] a heinous sin. To pretend that one is virtuous and to publicize that one is skilled and accomplished is also becoming a defeat (parajika). Therefore, the financial transactions must be done only by upasikas and upasikas. But, it is sad that upasakas and upasikas have not paid attention to this matter. It is easy to spread the rumour that the character of monks is not spotless. It is also heard that the gap of mutual trust between the upasakas and monks regarding money matters is widening these days. This is a case of misunderstanding, definitely not a pleasant matter... (pp. iii-iv)

Monks of Nepal are facing a big problem. They have no capacity to make adequate arrangements for fellow monks and Upasakas of Sri Lanka, Burma and Thailand during their visit to Nepal. Providing the facilities of boarding, lodging and transportation to the visiting monks and Upasakas and Upasikas has remained a big problem. The monks of Nepal are provided these facilities while visiting these countries. But, in Nepal, the monks have to be victims of humiliation sometimes while requesting the well-to-do Upasakas to provide the vehicles for the sight-seeing of the visiting monks and Upasakas... (p. vi)

There is another reason that makes a monk's life difficult. A monk's life is dependent on others. In the past monks could not live long without four things, e.g., chivara [robe], pindapatra [begging bowl], sayanasana [bedding], and medicine. Nowadays, these four things are not sufficient for the monks. Time has tremendously changed. Nowadays, monks have to buy books, pens, shoes, umbrella, etc. They have to construct or renovate viharas. The management of the above with the help of donors alone has become an impossibility. The attention of upasakas and upasikas is simply confined to the worship of the Buddha, inviting monks to the ceremonies like Annaprāsana, birthday and reciting the Paritrana after a death in the family. The monks are simply entangled in priestly functions [and] in activities that have nothing to do with their dharma-related works. For example, they are asked to take upasakas and upasikas to foreign countries on pilgrimages, bring foreign goods for them, get students admitted in schools and colleges, get jobs for their boys and girls etc. They are even involved in the job of matchmaking. Some [lay people] come to borrow money. Those monks who do not help them in such matters are neglected. [I]f they are unable to give lectures

due to illness or old age, they are neglected... I asked some people who had abandoned him, "Don't you go to Mahapragya nowadays?" They replied, "Now, there is no opportunity of hearing words of wisdom from him. He is unable to give sermons. Therefore, we do not go." After hearing so many words of wisdom, the people abandoned him when he was in bad health. Such is the fate of monks. (pp. 56-7)

With the change of time, the life style of the monks also changed. There are times when monks could not spend their time to please the upasakas. It is not proper to expect that monks should live as strictly as at the time of the Buddha. Some monks have been living a very unnatural and unbecoming life. It is not reasonable to say that the change of time and circumstance is responsible for the change in their character and conduct. There are reasons for the same, too. Some persons did not become monks after having acquired a good knowledge of Buddhism. They also do not learn much from the Acharya with whom they stay a year or so, nor is there a practice of teaching the same. The Acharyas are also not strict in providing education and explaining the teachings.

They consider their job done once they perform the rite of ordaining by giving the yellow robe. There are many people who became monks simply to get the facilities of a monk in expectation of foreign visits, respect and honour from the people, and education without spending money. There are a very few people who became monks out of dedication for the service of the people. It is still worse to become a monk in old age.

There were fake monks at the time of the Buddha as there are at present. For 20 years after the attainment of Supreme Enlightenment by the Buddha, the number of monks were few. The number of rules were few, too. Later, the number of monks increased by leaps and bounds. The condition of the Bhikshu Sangha worsened once the educated, lazy, unrestrained and ignorant people became monks. The formulation of many rules became inevitable. (pp. 57-8)

ENDNOTES

This paper draws on the research on Theravada Buddhism in Nepal that we have carried out intermittently between 1997 and 2004 (see LeVine & Gellner 2005).

For comments on earlier versions, we thank Richard Gombrich, Anil Shakyas, and participants in a workshop at Nanterre, Paris.

1. Locke (1985: 8) points out that, though viewed by Newar Buddhists today as Shakyamuni Buddha, some inscriptions identify the image as Akshobhya, the 'transcendental' Buddha who has the same earth-touching hand gesture as Shakyamuni. This can perhaps be taken as evidence that historicist interpretations of the nature of the Buddha, on the one side, and Tantric or cosmological ones, on the other, were not so distinct in the past.
2. A full set of rules of this sort can today only be observed in Kwa Baha, Lalitpur (Gellner 1991). In other Newar Buddhist temples the god-guardian often only carries out an elaborate ritual in the morning, and in a nod to monastic dress, removes his shirt from his right shoulder. The fullest study of this subject is Sharkey (2001).
3. On this ritual, see Gellner (1988) and von Rospatt (2005).
4. On traditional Newar Buddhism, see Locke (1980), Gellner (1992, 2001: chs 4 -7), Lewis (2000), and the website of the Lotus Research Institute (www.lrcnepal.com). On Shakyas titles, see Gellner (1989). On the history of Newar Buddhism, see Douglas (2002) and von Rospatt (2000).
5. The newly re-built Dharmakirti Vihara, the headquarters of the Theravada nuns in Nepal, combines a neo-traditional Newar façade with a thoroughly modern interior, complete with marble floors.
6. They were therefore in a quite different position from the, essentially secular, Magar ethnic activists of recent years who had decided they must break from Hinduism but were not sure what to put in its place. Both have ended up with Theravada Buddhism but by very different routes. The early Newar reformists were committed to celibate monasticism and only later came to a critique of Hinduism; the contemporary Magar activists started with a rejection of Hinduism for political and cultural reasons, without a fundamental commitment to celibacy, and have indeed started to train non-celibate priests, known as *pandits*, to carry out life-cycle rituals in a Theravada Buddhist idiom.
7. For these figures, see Kloppenborg (1977: 311), Gellner (1992: 322) Hartmann (1993: 77), and Kondanya (2001).
8. See LeVine & Gellner (2005: ch. 7) for details of the attempt to raise the nuns' status by taking *bhikkhuni pabbajja* from the Taiwanese Fo Guang Shan sect.

9. On Newar castes, see Toffin (1984) and Gellner & Quigley (1995). In contemporary Nepal the politics of caste and ethnicity now mean that ethnic activists claim that the Newar are just one group, belonging to the Janajati. The spokesmen of the low Newar castes have stated that they do not want to be included in the Dalit (ex-Untouchable) category (see Gellner 2003).
10. Technically Manandhars were not high caste, but Manandhars from Kathmandu had been upwardly mobile, educated, and often wealthy for two or three generations by then.
11. For this and the previous sentence we follow the Nepali translation. A *parajika* is an infraction of the monastic code so serious that the offender is automatically expelled from the Sangha.

REFERENCES

- Ashwaghosh, Bhikshu 2003. *The Life of a Monk*, ed. and tr. H.L. Singh. Kathmandu: D.D., B., R., & R. Shrestha. (Np. version, tr. Bh. Sangharakshita, 2002, published by Bh. Ashwaghosh.)
- Barnes, N.J. 2000. 'The Nuns at the Stupa: Inscriptional Evidence for the Lives and Activities of Early Buddhist Nuns in India' in E.B. Findly (ed.), *Women's Buddhism, Buddhism's Women: Tradition, Revision, Renewal*, pp.17-36. Boston: Wisdom Publications.
- Bartholomeusz, T. 1994. *Women Under the Bo Tree*. Cambridge: Cambridge University Press.
- Falk, M. L. 2000. 'Thammacarini Witthaya: The First Buddhist School for Girls in Thailand' In K.L. Tsomo, ed., *Innovative Buddhist Women: Swimming Against the Stream*, pp. 61-71. Richmond: Curzon.
- Douglas, W. 2002. 'The Fifteenth-Century Reinvention of Nepalese Buddhism.' D.Phil. diss., University of Oxford.
- Gellner, D.N. 1988. 'Monastic Initiation in Newar Buddhism' in R.F. Gombrich (ed.) *Indian Ritual and its Exegesis*, pp. 42-112. Delhi: OUP.
- Gellner, D.N. 1989. 'Buddhist Monks or Kinsmen of the Buddha? Reflections on the Titles Traditionally used by Sakyas in the Kathmandu Valley.' *Kailash* 15(1-2): 5-25.
- Gellner, D.N. 1991. 'A Newar Buddhist Liturgy: Sravakayanist Ritual in Kwa Bahah, Lalitpur, Nepal' in *Journal of the International Association of Buddhist Studies* 14 (2): 236-52.
- Gellner, D.N. 1992. *Monk, Householder, and Tantric Priest: Newar Buddhism and its Hierarchy of Ritual*. Cambridge: Cambridge University Press.

- Gellner, D.N. 1995. 'Sakyas and Vajracaryas: From Holy Order to Quasi-Ethnic Group' in Gellner & Quigley (eds), pp. 209-39.
- Gellner, D.N. 2001. *The Anthropology of Buddhism and Hinduism: Weberian Themes*. Delhi: Oxford University Press.
- Gellner, D.N. 2003. 'From Cultural Hierarchies to a Hierarchy of Multiculturalisms: The Case of the Newars of Nepal' in M. Lecomte-Tilouine and P. Dolfuss (eds) *Ethnic Revival and Religious Turmoil in the Himalayas*, pp. 73-131. Delhi: OUP.
- Gellner, D.N. & D. Quigley (eds) 1995. *Contested Hierarchies: A Collaborative Ethnography of Caste among the Newars of the Kathmandu Valley, Nepal*. Oxford: Clarendon.
- Gutschow, K. 2004. *Being a Buddhist Nun: The Struggle for Enlightenment in the Himalayas*. Cambridge MA: Harvard University Press.
- Hartmann, J.-U. 1993. 'Some Remarks on Caste in the Theravada Sangha of Nepal' in G. Toffin (ed.) *Nepal Past and Present*, pp. 73-81. New Delhi: Sterling.
- Kawanami, K. 2000. 'Patterns of Renunciation: the Changing World of Burmese Nuns' in E.B. Findly, ed., *Women's Buddhism, Buddhism's Women: Tradition, Revision, Renewal*, pp. 59-71. Boston: Wisdom Publications.
- Kloppenborg, R. 1977. 'Theravada Buddhism in Nepal.' *Kailash* 5: 301-322.
- Kondanya, Ven. 2001. 'Theravadian Records in Present Nepal' *The Charumati Voice [Kathmandu]*: 43-8.
- LeVine, S. 2000. 'At the Cutting Edge: Theravada Buddhist Nuns of Nepal.' in K.L. Tsomo (ed.) *Innovative Buddhist Women: Swimming Against the Stream*, pp. 13-29. Richmond: Curzon.
- LeVine, S. 2001. 'The Finances of a Twentieth-Century Buddhist Mission: Building Support for the Theravada Nuns' Order of Nepal' *JIABS* 24(2): 217-40.
- LeVine, S. & D.N. Gellner 2005. *Rebuilding Buddhism: The Theravada Movement in Twentieth-Century Nepal*. Cambridge MA: Harvard University Press.
- Liechty, M. *Suitably Modern: Making Middle-Class Culture in a New Consumer Society*. Princeton and Oxford: Princeton University Press.
- Locke, J. 1980. *Karunamaya: The Cult of Avalokitesvara-Matsyendranath in the Valley of Nepal*. Kathmandu: Sahayogi.
- Locke, J. 1985. *Buddhist Monasteries of Nepal: A Survey of the Bahas and Bahis of the Kathmandu Valley*. Kathmandu: Sahayogi.
- McNamara, J.A.K. 1996. *Sisters in Arms: Catholic Nuns Through the Millennia*. Cambridge: Harvard University Press.
- Moran, P. 2004. *Buddhism Observed: Travelers, Exiles and Tibetan Dharma in Kathmandu*. London and New York: RoutledgeCurzon.
- Rospatt, A. von. 2000. 'The Periodic Renovations of the Thrice Blessed Svayambhucaitya of Kathmandu.' Habilitation diss., Hamburg University.
- Salgado, N. 2000a. 'Teaching Lineages and Land: Renunciation and Domestication Among Buddhist Nuns in Sri Lanka' in E.B. Findly (ed.) *Women's Buddhism, Buddhism's Women*, pp. 175-200. Boston: Wisdom Publications.
- Salgado, N. 2000b. 'Unity and Diversity Among Buddhist Nuns in Sri Lanka' in K.L. Tsomo (ed.) *Innovative Buddhist Women: Swimming Against the Stream*, pp. 30-41. Richmond: Curzon.
- Schopen, G. 2004. *Buddhist Monks and Business Matters: Still More Papers on Monastic Buddhism in India*. University of Hawai'i Press.
- Sharkey, G. 2001. *Buddhist Daily Ritual: The Nitya Puja in Kathmandu Valley Shrines*. Bangkok: Orchid Press.
- Toffin, G. 1984. *Religion et Société chez les Néwar du Népal*. Kathmandu: CNRS.
- Tuladhar, S.M. 1996. 'Kindo Baha: A Center for the Resurgence of Buddhism in the Kathmandu Valley' *Lost Horizon* 3.
- von Rospatt, A. 2005. 'The Transformation of the Monastic Ordination (pravrajya) into a Rite of Passage in Newar Buddhism' in J. Gengnagel, U. Hüsken, & S. Raman (eds) *Words and Deeds: Hindu and Buddhist Ritual in South Asia*, pp. 199-234. Wiesbaden: Harrassowitz.