

Received Date: 17th October, 2025
 Revision Date: 20th November, 2025
 Accepted Date: 19th January, 2026

State Estimation of IEEE 5-Bus and 14-Bus Power System

Anil Basnet^{1*}, Anjan Roka², Aayusha Thapa³

¹Dept of Electrical Engineering, Pulchowk Campus, TU, Nepal. E-mail: 077bel004.anil@pcampus.edu.np

²Dept of Electrical Engineering, Pulchowk Campus, TU, Nepal. E-mail: 077bel006.anjan@pcampus.edu.np

³Dept of Electrical Engineering, Pulchowk Campus, TU, Nepal. E-mail: 077bel002.aayusha@pcampus.edu.np

Abstract— This paper investigates techniques for precisely estimating the state (angles and voltages) of electrical networks using the 5-bus and 14-bus test systems. Two methods were examined: Weighted Least Squares (WLS), a statistical technique used to minimize measurement errors; and the Artificial Neural Network (ANN), a machine learning model trained to estimate the system states. The results showed that WLS provided reliable estimates with fewer measurements, while ANN yielded the most accurate results overall. This study contributes to the enhancement of real-time power grid monitoring, thereby supporting a stable and consistent electricity supply.

Keywords — State estimation, ANN, WLS, DSE, IED, RMSE

I. Introduction

State estimation is the process of determining the internal state of an energy system, by a mathematical model and input/output data measurements. State estimation algorithms are fundamentals to many analysis, monitoring and energy management tasks. To solve many energy systems and control problems the knowledge of the energy system's state is necessary. State estimation for electric transmission grids was first formulated as a weighted least-squares problem by Fred Schweppe and his research group in 1969 also developed spot pricing, the precursor of modern-day locational marginal prices – LMPs – a central feature of electricity markets)[1]. A state estimator is a central part of every control center.

The power system consists of complex networks of generation, transmission, sub-transmission, and distribution channels. Additionally, these transmission channels consist of various interconnected substations for converting the voltage and current into the required level, and other devices for system monitoring, controlling, and protection. Power may be either injected into the system by the generator or absorbed by the load, or by the generator due to certain faults and undesired events. The operating conditions of the

* Corresponding Author

power system can be determined if the network parameter and the complex phasor voltage are known. If the loads are supplied with adequate active and reactive power as per their requirement by the connected generators, and the operational constraints are within the limit, the system is said to be in normal conditions. Despite some common contingencies and failures of the transmission system caused by natural phenomena such as storms, the power at each bus might be within limits but is vulnerable to which insecure state of power flow is called an emergency state, and corrective control action must be undertaken during such period. Such preventive controls can be determined typically by the help of a security constrained optimal power flow program which accounts for a list of critical contingencies.

Hence, it is essential to either calculate or accurately estimate the bus voltage, phase angle, and active and reactive power either injected or supplied onto the power distribution network to identify the state of the system. DSE is capable of accurately capturing the dynamics of the system states, and will play an important role in power system control and protection [2]. With the widespread deployment of phasor measurement units (PMUs) and advanced communication infrastructure in power systems, the development of a fast and robust DSE tool has become possible[2]. Power system SE can be subjected to different types of anomalies that might spoil the accuracy of the estimated states[3].

The basic motivation for state estimation is that we want to perform computer analysis of the network under the conditions characterized by the current set of measurements. Specifically, we want to know the values of the bus voltage phasor magnitudes and angles θ_k for all $k=1, N$ buses in the network (we assume $\theta_1=0$ so we do not need to find that one). This has led to various research on different estimation techniques including WLS and ANN.

Root-mean-square error (RMSE) was used to compare the proposed technique with existing methods, showing improved accuracy over the tracking method and Holt's exponential smoothing technique, especially at bus 17 in the

IEEE 30-bus network[4].

These currently estimated states were used for synthetic data generation for better-supervised learning schemes. With such a dataset being developed, a comparative analysis among several machine learning, regression, TDNN and ARIMA have been done for proper forecasting of operating states [5]. In this paper, the standard IEEE 14 bus system has been taken as a test bench for forecasting the states of the system.

Modeling state dynamics and correlations explicitly is challenging due to unknown underlying physics and the presence of random behaviors. This is where machine learning becomes valuable in state estimation[6]. The Artificial Neural Network (ANN) is employed for short-term load forecasting in the paper, where it defines a discrete-time state transition model for estimating states dynamically and generating pseudo measurements [7]. In supervised learning algorithms, one of the most popular methods is backpropagation, in which the activation function should be differentiable[8].

II. Materials and Methods

This paper presents independent methodologies –Weighted Least Square Method (WLS) and Artificial Neural Network (ANN) –to estimate the system states variables i.e. voltage and angle of IEEE 5 and 14 bus power system. The output from both approaches are compared to calculate the root mean square and accuracy of each method.

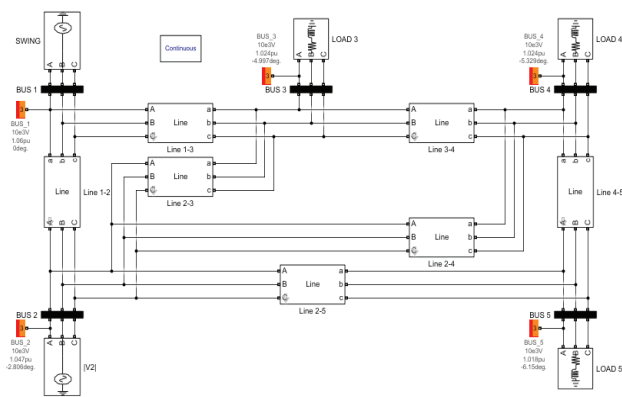

Fig 1: IEEE-5 bus model

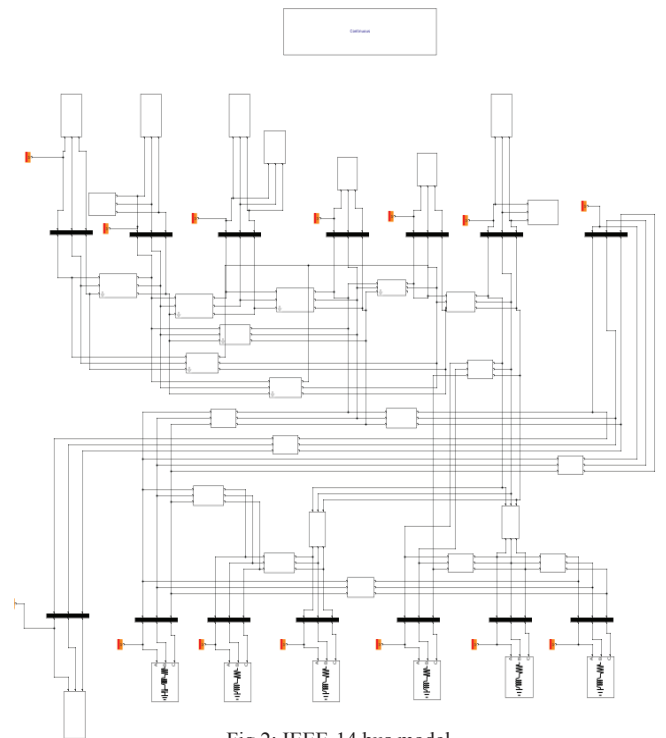

Fig.2: IEEE-14 bus model

Weighted Least Method Estimation:

It is one of the fundamental and traditional state estimation techniques whose objective function is to minimize the square of error. It provides an optimal estimation under Gaussian noise conditions and also is use full for bad data detection.

Mathematical Formulation

The state estimation problem is formulated as:

$$J(x) = [z - h(x)]^T W [z - h(x)] \quad \dots (1)$$

Where,

z is the measurement vector,

$h(x)$ represents the nonlinear relationship between measurements and system states,

W is the weight matrix,

x is the state vector (voltage magnitude and phase angle)

The optimal state estimate x^* is obtained iteratively using the Newton–Raphson method:

$$x^{k+1} = x^k + [H^T W H]^{-1} H^T W [z - h(x^k)] \dots (2)$$

Where, H is the Jacobian matrix of $h(x)$.

This iterative process continues until the convergence criterion

$\|x^{k+1} - x^k\| < \epsilon$ is satisfied.

Measurement Model

The mathematical relationship between system states and measurements is:

$$\bar{z} = H\bar{x} + \bar{e} \dots (3)$$

Where,

\bar{z} = measurement vector,

\bar{x} = state variable vector,

H = Jacobian matrix (sensitivity of measurements to states),

\bar{e} = measurement error vector.

Individually, each measurement can be written as:

$$Z_1 = h_{11}x_1 + h_{12}x_2 + e_1 \dots (4)$$

$$Z_2 = h_{21}x_1 + h_{22}x_2 + e_2 \dots (5)$$

$$Z_3 = h_{31}x_1 + h_{32}x_2 + e_3 \dots (6)$$

$$Z_4 = h_{41}x_1 + h_{42}x_2 + e_4 \dots (7)$$

This model relates measurable quantities (voltages, currents, etc.) to unknown state variables.

Weighted Least Squares Function:

The objective function of WLS is:

$$f = \sum_{i=1}^m w_i e_i^2 = w_1 e_1^2 + w_2 e_2^2 + w_3 e_3^2 + w_4 e_4^2 \dots (8)$$

Where, w_i are the measurement weights, usually, $w_i = \frac{1}{\sigma_i^2}$ (inverse of the variance).

Minimizing f reduces the total weighted error across all measurements.

Taking the derivative of f with respect to each state variable and setting it to zero gives:

$$H^T w(\bar{z} - H\bar{x}) = 0 \dots (9)$$

Substituting these derivatives, we obtain:

$$H^T W \bar{e} = 0 \dots (10)$$

WLS State Estimation Formula:

Solving the above equation gives the state estimation equation:

$$H^T w(\bar{z} - H\bar{x}) = 0 \dots (11)$$

Simplifying,

$$H^T W \bar{z} = H^T W H \bar{x} \dots (12)$$

Hence, the estimated state vector is given by:

$$\hat{x} = (H^T W H)^{-1} H^T W \bar{z} \dots (13)$$

Where:

$H^T W H$ is known as the gain matrix G ,

W represents the weight (inverse covariance) matrix, and

\bar{z} is the vector of measured quantities.

Thus,

$$\hat{x} = G^{-1} H^T W \bar{z} \dots (14)$$

Error and Residual Analysis:

Considering the true measurement model:

$$z = H\bar{x} + \bar{e} \dots (15)$$

Substituting this into the estimator gives:

$$\bar{x} = \bar{x} + G^{-1} H^T w \bar{e} \dots (16)$$

Thus, the estimation error is:

$$\hat{\bar{x}} - \bar{x} = G^{-1} H^T w \bar{e} \dots (17)$$

The residual (difference between measured and estimated quantities) is expressed as:

$$\bar{e} = (I - H G^{-1} H^T w) \bar{e} \dots (18)$$

Artificial Neural Network Estimation:

ANN is a biologically inspired computer program designed to simulate the way in which the human brain processes information. ANNs are used to find relationships that are difficult to describe explicitly and are especially appropriate and powerful because weights and biases can implicitly represent a given function.

ANN Structure:

The ANN consists of an input layer, several hidden layers, and an output layer, with each neuron in one layer fully connected to the next. The input layer includes the active and reactive power of all buses ($P_i, Q_i, P_p, Q_i, P_p, Q_i$), the swing bus voltage (V_1), and its phase angle (δ_1). The output layer

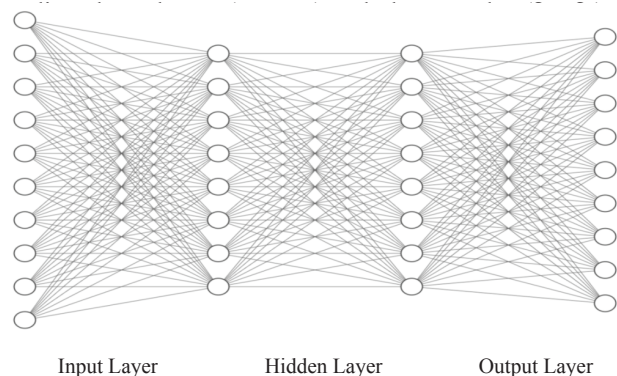

Fig.3: ANN Structure

Data Preparation, Scaling, and Learning Rate:

Training data were generated through power flow simulations and the Weighted Least Squares (WLS) method to ensure realistic system conditions. The dataset was then loaded, separated into input and output variables, and divided into training, testing, and validation subsets. All data were normalized to maintain numerical stability and ensure that each feature contributed proportionally to model learning.

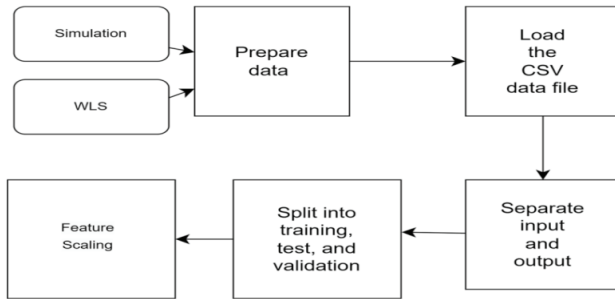

Fig.4: Data Preparation and Scaling

The learning rate (η) controls how much the network's weights are updated during backpropagation. A high learning rate may cause oscillation around the optimal solution, while a very low rate slows down convergence. To balance both, a decaying learning rate was applied, starting relatively high and gradually decreasing, to allow faster initial training and more precise final tuning. This method improves both stability and generalization.

ANN Model Design

The developed ANN is a fully connected sequential network composed of seven layers. Dropout layers with rates between 0.1 and 0.3 are included to prevent overfitting by randomly disabling some neurons during training. The network uses the sigmoid activation function:

$$S(x) = \frac{1}{1 + e^{-x}} \quad \dots (19)$$

Which introduces smooth nonlinearity and supports normalized data processing. The model is compiled with Mean Squared Error (MSE) as the loss function and trained using the Adam optimizer, known for its adaptive learning capability. Training was carried out for 31 epochs, with validation data used continuously to track performance.

Validation and Performance:

Validation ensures that the model performs effectively on unseen data. During training, both training and validation losses decreased smoothly, showing that the model learned the desired mapping without over-fitting. The nearly parallel trends of the two losses indicated strong generalization ability and model stability.

Table I

Voltage Magnitudes and Angle for Buses

Bus	Angle Deviation (rad)	Voltage (p.u)
1	0.00 (ref)	1.06094747
2	-0.04887837	1.04833448
3	-0.08705863	1.02517545
4	-0.09285274	1.02457765
5	-0.10714617	1.01887957

$$S(x) = \frac{1}{1 + e^{-x}}$$

Sigmoid Function

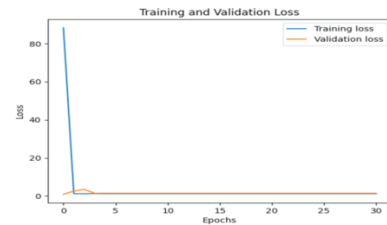

Fig.5 Training and validation loss

III. Tests and Results

A. IEEE - 5 bus system

1. State estimation using WLS.

In this case, we provided input measurements from PMUs and other various measuring devices. The total number of input features was 23.

Number of State Variables: 9

At Significance level (α) = 0.005

To evaluate the accuracy of the model, we calculate the chi-square value (χ^2) for the system.

The critical value of the chi-square for $k = 14$ and $\alpha = 0.005$ is:

$$\chi_{critical}^2 = 4.075$$

Now, the calculated value of the actual chi-square based on our data:

$$\chi_{calculated}^2 = 0.0087262029$$

Acceptance Criteria:

- If $\chi_{calculated}^2 \leq \chi_{critical}^2$, the model is considered accurate with the specified confidence.

- If $\chi_{calculated}^2 > \chi_{critical}^2$, the model may not meet the desired accuracy, and further adjustments may be necessary.

Since, $\chi_{calculated}^2 \leq \chi_{critical}^2$, the observed data are consistent

with the expected model with a very high confidence level of 99.5

2. *Bad Data Detection Using WLS method:*

One of the main advantages of WLS is the detection and correction of measurement errors. When the chi-square value lies outside the acceptance region, erroneous data is detected and eliminated to yield robust state estimation.

To demonstrate this, we introduced an incorrect measurement in the power flow data from bus 3 to bus 5.

Table II
Voltage Magnitudes and Angle for Buses

Bus	Angle Deviation (rad)	Voltage (p.u)
1	0.00 (ref)	1.06094747
2	-0.04887837	1.04833448
3	-0.08705863	1.02517545
4	-0.09285274	1.02457765
5	-0.10714617	1.01887957

The chi-square value is compared with the critical value of the chi-square distribution table for k = 14 degrees of freedom at the chosen significance level $\alpha = 0.99$.

$$\chi^2_{critical} = 29.141$$

Now, the calculated value of the actual chi-square based on our data:

$$\chi^2_{calculated} = 35.81437523706366$$

Since, $\chi^2_{calculated} > \chi^2_{critical}$, the observed data aren't consistent with the expected model and with a very high confidence level of 99% to lies outside the significant value.

Through bad data detection, we identified and removed the erroneous measurement, then reanalyzed the data to obtain accurate results. We obtained:

Table III
Voltage Magnitudes and Angle for Buses

Bus	Angle Deviation (rad)	Voltage (p.u)
1	0.00 (ref)	1.0598
2	-0.049	1.0472
3	-0.0872	1.024
4	-0.0931	1.0235
5	-0.1074	1.0176

k = 13

$$\chi^2_{critical} = 3.565$$

Now, the calculated value of the actual chi-square based on our data:

$$\chi^2_{calculated} = 0.008696776324816788$$

Since, $\chi^2_{calculated} < \chi^2_{critical}$, the observed data are consistent with the expected model with a very high confidence level of 99.5.

3. *State estimation using ANN.*

Table IV
Voltage Magnitudes and Angle for Buses

Bus	Angle Deviation (rad)	Voltage (p.u)
1	0.00 (ref)	1.06034522
2	-0.04888132	1.04774855
3	-0.08769688	1.02433595
4	-0.09349707	1.02374261
5	-0.10640075	1.01858576

B. *IEEE - 14 bus system*

1. *State estimation using WLS*

Table V
Voltage Magnitudes and Angle for Buses

Bus	Angle Deviation (rad)	Voltage (p.u)
1	0.00000000 (ref)	1.05998508
2	-0.08685849	1.0450068
3	-0.22175614	1.01000352
4	-0.18053375	1.02000508
5	-0.15346605	1.02100400
6	-0.24880897	1.07000692
7	-0.23289398	1.07701570
8	-0.23289401	1.11001637
9	-0.26020965	1.05201921
10	-0.26316739	1.04802895
11	-0.25823497	1.05501203
12	-0.26369436	1.05500709
13	-0.26495224	1.05000771
14	-0.27980660	1.03301313

In this case, we provided input measurements from PMUs and other various measuring devices. The total number of input features was 67.

Significance level (α) = 0.005

The chi-square value is compared with the critical value of the chi-square distribution table for k = 40 degrees of freedom at the chosen significance level $\alpha = 0.005$. The critical value of the chi-square for k = 40 and $\alpha = 0.005$ is:

$$\chi^2_{critical} = 20.707$$

$$\chi^2_{calculated} = 4.503427350051661$$

Since, $\chi^2_{calculated} < \chi^2_{critical}$, this means that the observed data are consistent with the expected model with a very high confidence level of 99.5.

2. *Bad Data Detection using WLS method*

To demonstrate this, we introduced an incorrect measurement in the reactive power at bus number 7. To evaluate the precision of the model, we calculate the chi-square value (χ^2) for the system. The chi-square value is compared with the critical value of the chi-square distribution table for $k = 40$ degrees of freedom at the chosen

Table VI

Voltage Magnitudes and Angle for Buses

Bus	Angle Deviation (rad)	Voltage (p.u)
1	0.00 (ref)	1.04206515
2	-0.0893361	1.02720581
3	-0.22289821	0.99375021
4	-0.18656731	1.00187483
5	-0.15886819	1.00282372
6	-0.25848082	1.05214196
7	-0.24234607	1.0595277
8	-0.24264071	1.09325279
9	-0.2707253	1.0342007
10	-0.27386736	1.03015758
11	-0.26863242	1.0371855
12	-0.27415048	1.03716542
13	-0.27543435	1.03201953
14	-0.29116195	1.01487908

significance level $\alpha = 0.99$.

$\chi^2_{critical} = 63.691$

$\chi^2_{calculated} = 105.84530295864062$

Since, $\chi^2_{calculated} > \chi^2_{critical}$, the observed data aren't consistent with the expected model and with a very high confidence level of 99% to lie outside the significant value.

Through bad data detection, we identified and removed the erroneous measurement, then reanalyzed the data to obtain accurate results. We obtained the following: $k = 39$, $\chi^2_{critical} = 20.015$

$\chi^2_{calculated} = 0.021388742272603716$

Since, $\chi^2_{calculated} < \chi^2_{critical}$, finally, this means that the observed data are consistent with the expected model with a very high confidence level of 99.5.

Table VII

Voltage Magnitudes and Angle for Buses

Bus	Angle Deviation (rad)	Voltage (p.u)
1	0.00000000 (ref)	1.0596
2	-0.0869	1.0447

3	-0.2219	1.0097
4	-0.1806	1.0196
5	-0.1535	1.0206
6	-0.2490	1.0696
7	-0.2330	1.0767
8	-0.2331	1.1120
9	-0.2603	1.0516
10	-0.2633	1.0477
11	-0.2584	1.0547
12	-0.2638	1.0547
13	-0.2651	1.0496
14	-0.2801	1.0326

3. *State estimation using ANN*

Table VIII

Voltage Magnitudes and Angle for Buses

Bus	Angle Deviation (rad)	Voltage (p.u)
1	0.00 (ref)	1.05999532
2	-0.0868571	1.04501698
3	-0.22175542	1.01001284
4	-0.18053038	1.02001544
5	-0.15346304	1.02101439
6	-0.2488036	1.07001714
7	-0.23288873	1.07702568
8	-0.2328886	1.11002597

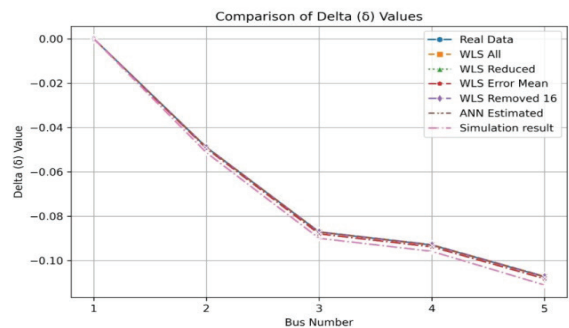
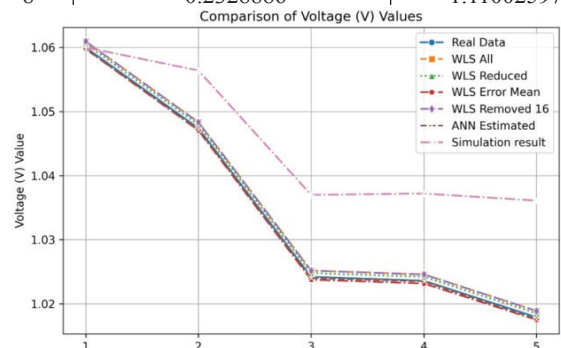

Comparison graph between WLS and ANN of 5-Bus system

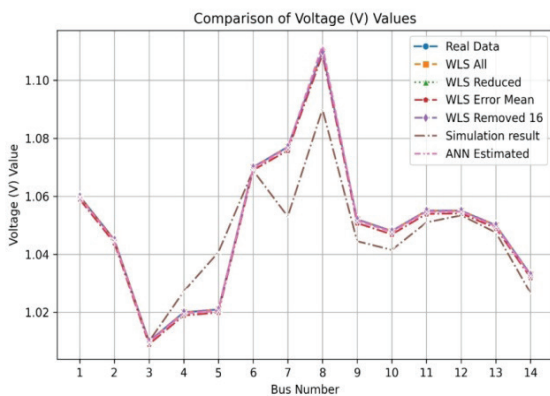
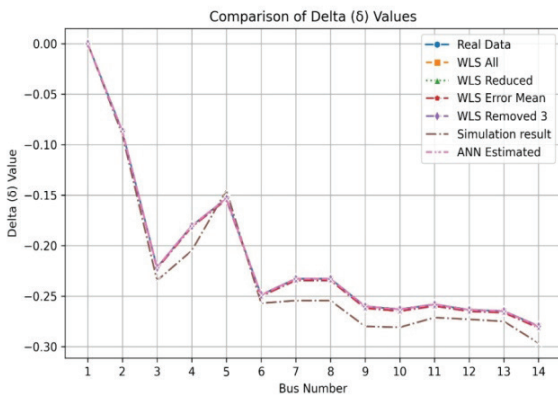

Comparison graph between WLS and ANN of 14-Bus system

IV. Discussion

Through the research, we evaluated performance of 5 and 14 bus systems using Root Mean Square Error (RMSE) and bad data detection. These two types of buses were analyzed using methods Weighted Least Square (WLS) and Artificial Neural Network (ANN). The result obtained illustrated the lowest deviation in both voltage magnitude and phase angle estimations in case of ANN. ANN thus possesses superior performance than WLS method contributed by its strong capability in capturing nonlinearity and providing accurate estimations.

Talking about the 5-bus system, the RMSE values were 0.000048 for phase angle and 0.000210 for voltage, which are the smallest figures. Similarly, ANN maintained RMSE results 0.000112 for phase angle and 0.000636 for voltage. Meanwhile, WLS showed good results even with limited data available.

Nevertheless, the limitations of ANN should also be addressed to explore ways for refinement. The high dependency of performance of ANN on quality or diversity of training data might deteriorate the outcome if these

factors are not obtained carefully. Expanding the dataset can help improve the training process. We were able to detect bad data and remove using WLS technique.

Overall, comparing ANN and WLS, ANN offered the most accurate and stable estimation. However, WLS also showed unique significance through its ability to estimate under reduced conditions. Therefore, while ANN can be used to produce closest estimation, during limitation of data, WLS has been proved to become useful.

V. Conclusion

The purpose of this research was to find the best state estimator among WLS and ANN for Power System State Estimation (PSSE) of IEEE-5 and IEEE-14 bus systems. Both methods were successfully employed and analyzed on the basis of different techniques. Through extensive simulations and analysis, we observed that both methods were able to provide the accurate results. The simulation conducted revealed that ANN shows the most accurate state estimates for both systems, and WLS also provided outstanding results. All set objectives were accomplished and satisfactory output was obtained. The error was calculated using the root mean square method (RMSE). Additionally, a chi-square distribution test was performed for the WLS method. The creation of hybrid models, which integrate several estimation approaches to improve power system state estimation's accuracy and resilience, is a promising avenue for further study. Furthermore, more accurate dynamic state estimation would be made possible by incorporating renewable energy sources like wind farms, solar photovoltaics (PV), and other alternative generation sources. A thorough examination of system stability under varied operating conditions would also be possible with this method. This paper provides valuable insight on the state estimation of power systems which is important for optimizing power system performance in presence of measurement errors and system uncertainties. The results presented here are based on simplified IEEE test systems due to which findings might differ when applied to larger systems, more complex real-world networks.

Acknowledgement

The authors would like to express our sincere gratitude to all those who supported and guided us throughout the successful completion of our final year project. Special thanks to Asso. Prof. Dr. Basanta Gautam, Head of the Department of Electrical Engineering, for providing all necessary resources and a supportive academic environment.

Our sincere appreciation goes to all faculty members and lab staff of the department for their assistance and insights during the project duration. Additional thanks to Kathmandu Engineering College (KEC) for providing an excellent platform and venue for us to present and publish this research, fostering our academic and technical growth and supporting its successful publication.

References

- [1] Schweppe, F.J.I.T.P.A.S., *Power system state estimation, parts I, II and III*. 1970. **89**: p. 120-135.
- [2] Zhao, J., et al., *Power system dynamic state estimation: Motivations, definitions, methodologies, and future work*. 2019. **34**(4): p. 3188-3198.
- [3] Asefi, S., et al., *Anomaly detection and classification in power system state estimation: Combining model-based and data-driven methods*. 2023. **35**: p. 101116.
- [4] Hassanzadeh, M. and C.Y. Evrenosoğlu. *Power system state forecasting using regression analysis*. in *2012 IEEE Power and Energy Society General Meeting*. 2012. IEEE.
- [5] Mukherjee, D., S. Chakraborty, and S.J.E.E. Ghosh, *Power system state forecasting using machine learning techniques*. 2022. **104**(1): p. 283-305.
- [6] Wang, L., et al., *Physics-guided deep learning for power system state estimation*. 2020. **8**(4): p. 607-615.
- [7] Goleijani, S. and M.T.J.I.t.o.e.e.s. Ameli, *Neural network based power system dynamic state estimation using hybrid data from SCADA and phasor measurement units*. 2018. **28**(2): p. e2481.
- [8] Rumelhart, D.E., G.E. Hinton, and R.J.J.n. Williams, *Learning representations by back-propagating errors*. 1986. **323**(6088): p. 533-536.